

MotorGuide® REPAIR PARTS

Model:
QS320V

SPECIFICATIONS:

Year of Intro	1996
Thrust	37LBS
Volts	12VDC
Amp Draw	0 to 48 amps
Mount	03 Transom
Speeds	Variable

QUICK REFERENCE PARTS GUIDE:

Rotary Switch	KT150-02
ON/OFF Switch	TT3149-03
DA Board	JF157-03
MOSFET	JF096-07
Motor Seal Kit	6220
Slide Pot	TT168-06

PARTS ORDERING & TECH ASSISTANCE

MotorGuide Consumer Relations
Phone 918-831-6989
Fax 800-982-8093

Send Returned Goods to:
MotorGuide
605 Hwy 12 West
Starkville, MS 39760

Returned Goods must be accompanied with a Returned Goods Authorization. Contact MotorGuide Consumer Relations to obtain RGA.

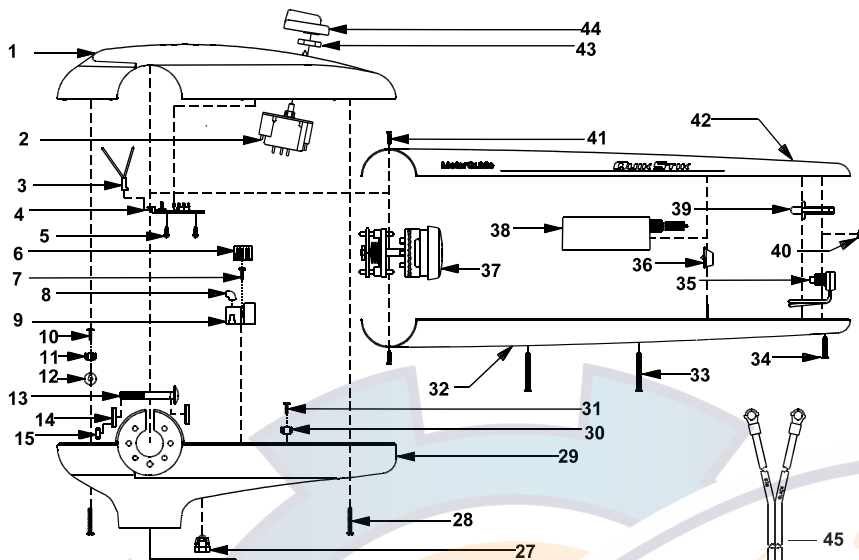

TO REVERSE TROLLING MOTOR HEAD:

1. REMOVE THE THREE TOP HOUSING COVER SCREWS (AR133-01)
2. REMOVE THE COLUMN NUT (XT098-02)
3. REMOVE THE COLUMN BOLT (TT134-01)
4. ROTATE THE TOP HOUSING BASE (TT004-10) 180 DEGREES
5. REINSTALL THE BOLT, (BEING CAREFUL NOT TO NICK OR DAMAGE THE MOTOR WIRES), NUT AND TOP HOUSING SCREWS IN REVERSE ORDER

-Apply 1.5 ML (7 drops) LOCTITE 262 (Red).
-Torque to 30-40 lb-ft.
-Wipe off any excess LOCTITE.
-Align either pair of column holes parallel with armature shaft +/- 1.5°.

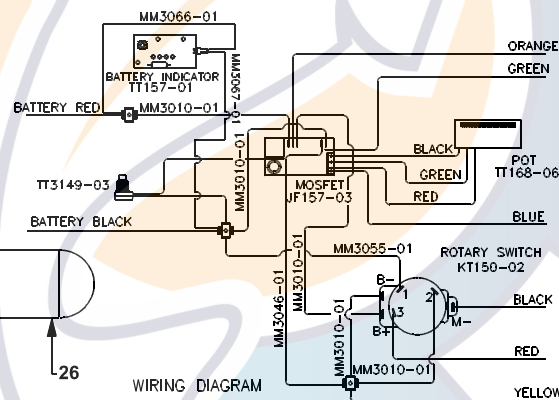

NOTE: INSULATING SLEEVE AT080-01, GOES ON ORANGE AND BLACK (TERMINAL B) WIRES ON MOSFET BOARD.

KEY#	PART#	DESCRIPTION	KEY#	PART#	DESCRIPTION
1	TT053-10	COVER 5 SPD QS GENERIC	26	KF397-03	LOWER UNIT
2	KT150-02	ROTARY SWITCH	27	GR019-01	BATTERY CABLE BUSHING
3	WF329-01	CONNECTOR/JUMPER ASY	28	AR133-01	8 X 1 3/8 SCREW
4	TT157-01	BATTERY LEVEL INDICATOR	29	TT004-10	T/H BASE GENERIC
5	AF141-01	SELF TAPPING SCREW	30	FT160-03	TERMINAL 4 PRONG
6	AP029-01	AMP CONNECTOR	31	GR133-01	310 X 1/2 SCREW
7	AF141-01	SELF TAPPING SCREW	32	TT072-05	LOWER HANDLE QS BLACK
8	AT080-01	INSULATING SLEEVE	33	TT133-03	#6 X 1" SCREW
9	JF157-03	12V DURA AMP BOARD	34	TT133-02	#6 X .75 SCREW
10	GR133-01	310 X 1/2 SCREW	35	TT3149-03	ON/OFF SWITCH ASY
11	FT160-03	TERMINAL (4 PRONG)	36	TT3001-03	ACTUATOR ASY
12	TT098-03	ON SERT PAL NUT	37	TT372-04	HANDLE CLUTCH ASY
13	TT134-01	BOLT	38	TT168-06	POTENTIOMETER
14	TT171-04	CURVED WASHER	39	TT001-04	ACTUATOR ON/OFF
15	XT098-02	NYLON LOCK NUT	40	TT177-02	SWITCH BOOT
16	AR082-02	BAR KNOB DEPTH ADJUST	41	TT133-01	#6 X .437 SCREW
17	AR171-01	COLUMN CLAMP WASHER	42	TT072-12	UPPER HANDLE
18	FR098-01	COLUMN SUPPORT NUT	43	AT098-01	PAL NUT
19	AR051-01	DEPTH ADJUST COLLAR	44	TT082-06	ROTARY KNOB
20	TT049-04	COLUMN 30"	45	TT328-05	BATTERY CABLE ASY
	FR049-15	COLUMN 42"			
21	ET060-04	LOWER UNIT DECAL			
22	AR175-01	MONOFILAMENT WASHER			
23	BR102-01	PROP PIN			
24	AF124-10	3 BLADE PROP			
25	AR099-01	PROP NUT			

PARTS NOT ILLUSTRATED

NT056-07	DECAL
MM5604	OWNERS MANUAL

Model:
QS320V

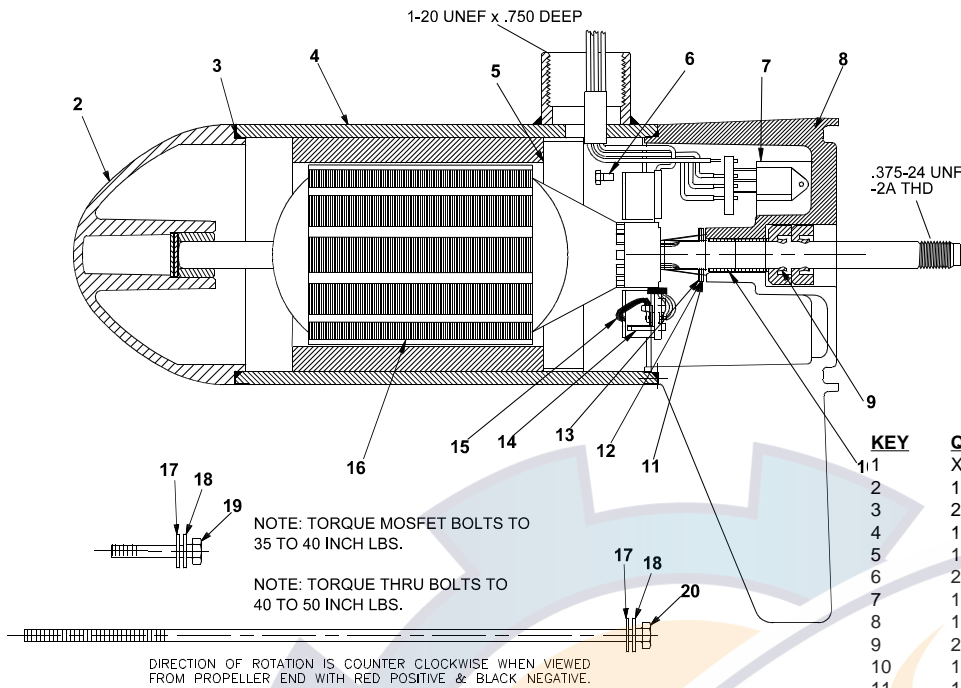

KEY	QTY	DESCRIPTION	PART NO.
1	X	MOTOR	KF397-03
2	1	NOSE CAP	JF3212-01
3	2	O RING SEAL	MR217-01
4	1	HOUSING ASY	KF3210-01
5	1	RETAINER	JF233-01
6	2	BRUSH CARD SCREW	MR228-01
7	1	DURA AMP MODULE	JF096-07
8	1	COMM CAP	JF3205-04
9	2	SHAFT SEAL	MR223-01
10	1	BEARING	MR206-01
11	1	NYLATRON WASHER	MR226-01
12	1	WASHER	MR227-01
13	1	E RING	MR219-02
14	2	BRUSH SPRINGS	MR214-02
15	1	BRUSH ASY LESS SPRING	JF3201-01
16	1	ARMATURE 3.5"	KF3207-01
17	4	STATIC SEAL	MR222-01
18	4	THRU BOLT WASHER	MR216-01
19	2	DURA AMP SCREW	MR229-04
20	2	THRU BOLT	MR218-01

WIRING

